

PULL-LOCK INSTALLATION GUIDE

December 1, 2007

Cable Art, Inc.
25334 Avenue Stanford
Valencia, CA 91355
877-664-4224

661-257-7522
Fax 661-257-7502

e-mail: sales@cableart.com
www.cableart.com

Pull-Lock™ Stop-end (non-tensioning) Fittings Installation Instructions



Make sure the holes are drilled properly in the posts where you will be installing your fittings.

If you are installing the fittings in a metal railing, see *Metal Railings/Hardware Mounting Holes/Boring Guide* for boring instructions.

If you are using wood end posts, see "Wood Railings-Mounting Alternatives" section in the Installation Guide (Page17) for hole sizes.

For wood, first drill a pilot hole through the post that is 1/32" larger than the diameter of the cable you are using. (It is best to drill the pilot hole from one side about half-way through the post and then drill from the other side to complete the hole.) Then drill a 29/64" hole from the back side of the post at least 1-5/8" deep (deeper if you are counterboring for the over-sized washer).

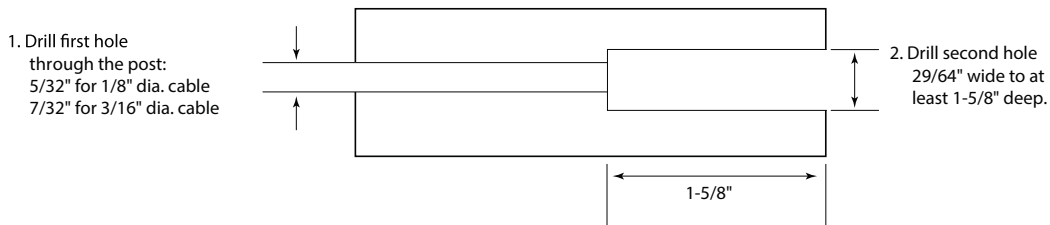

1. Following the instructions elsewhere in this guide for the tensioning device you will be installing on one end of the cable run, install the tensioning device to your end post on one end of the cable run first (Post A below).

Post A



Tensioning Device

Post B



Pull-Lock™ Fitting

2. Run the cable through the intermediate posts (if any) and through Post B where you will be installing the Pull-Lock™ Fittings.

Post A



Tensioning Device

Post B



Pull-Lock™ Fitting

3. Cut the cable with a cable cutter, leaving enough cable extending out from the back side of the post to be able to grasp the cable firmly with your hand (6" or more).

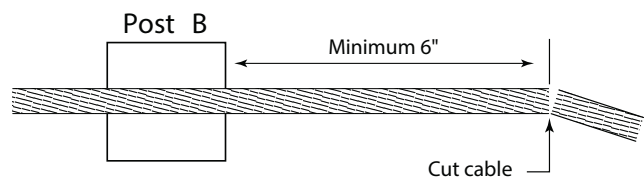

4. Slip the washer over the body of the Pull-Lock™ Fitting (11HW14 washer for wood posts, 20HWD4B black Delrin washer for metal posts).



5. Push the cable into the hole in the front of the Pull-Lock™ Fitting and pull the cable through the fitting. Twist the cable in the right-hand direction (with the lay of the cable) as you push it into the fitting. Then slide the fitting along the cable and up to the back side of the post.

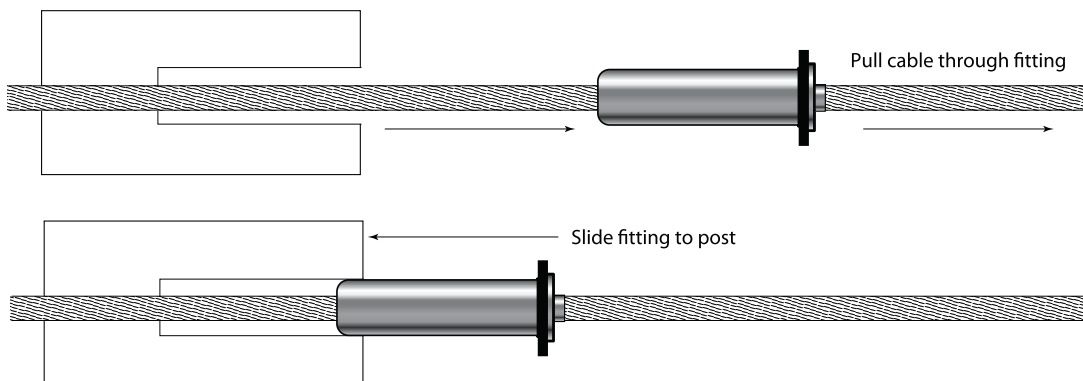

6. Hold the cable with one hand and slide the Pull-Lock™ Fitting into the hole in the post. Press on the back of the Pull-Lock™ fitting to hold it securely in the post and pull the cable through the fitting until it is as tight as you can make it.

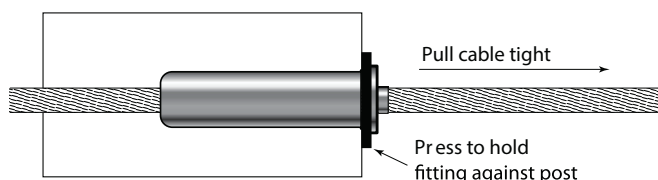

7. Cut the cable flush with the hole in the back of the Pull-Lock™ Fitting, using a cut-off wheel.

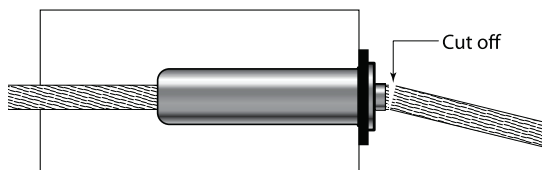

8. Pull the cable to set the gripping action of the Pull-Lock™ Fitting.

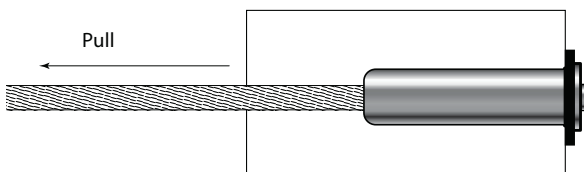

9. Press the cap onto the lip of the Pull-Lock™ Fitting.

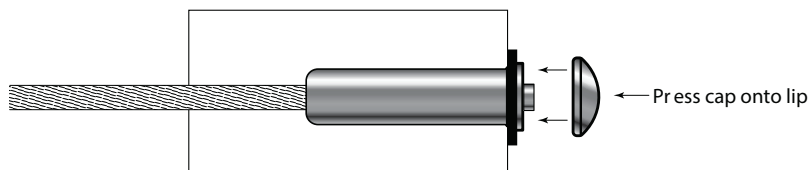

10. Tension the cable with the tensioner installed on the end post (Post A) at the other end of the cable run, after all the fittings have been installed in both end posts.